



PROVINCE OF QUEBEC
TOWN OF KIRKLAND

DRAFT
BY-LAW NO: 90-58-100

**BY-LAW AMENDING ZONING BY-LAW NO. 90-58 IN
ORDER TO ENSURE ITS CONCORDANCE WITH THE
PROVINCIAL RESIDENTIAL SWIMMING POOL
SAFETY REGULATION**

ADOPTION PROCEDURE

Notice of motion:	October 4, 2021
Adoption – draft:	October 4 2021
Publication:	October 8, 2021
Public consultation:	Until October 25, 2021
Adoption – Second draft:	November 15, 2021
Publication:	November 17, 2021
Application request:	
Registration procedure:	
Adoption of by-law:	
Certificate of conformity:	
Publication:	
Coming into force:	

- CONSIDERING that the provincial government has adopted the *Residential Swimming Pool Safety Act* (CQLR, c. S-3.1.02) under which the Government may, by regulation, set residential swimming pool safety standards;
- CONSIDERING that local municipalities are responsible for ensuring compliance with the *Residential Swimming Pool Safety Regulation* (CQLR, c. S-3.1.02, r. 1);
- CONSIDERING that notice of motion of this by-law was given and that adoption of the draft was done at the regular sitting of the municipal Council held on October 4, 2021;
- CONSIDERING that in accordance with section 356 of the *Cities and Towns Act* (CQLR, c. C-19), copies of this draft by-law were made available to the public;
- CONSIDERING that the preamble forms an integral part of this by-law;

THE MUNICIPAL COUNCIL DECREES THE FOLLOWING:

SECTION 1

The following definitions are added to Appendix 1 of *Zoning By-Law no. 90-58* in alphabetical order:

“SWIMMING POOL:

A permanent or temporary artificially constructed outdoor basin intended for swimming that has a water depth equal to or greater than 60 cm and to which the Regulation respecting safety in public baths (chapter B-1.1, r. 11) does not apply, but excludes whirlpools and hot tubs where their capacity does not exceed 2,000 litres.”

“INGROUND OR SEMI-INGROUND POOL:

A swimming pool that is partially or completely buried under the ground surface.”

“ABOVEGROUND POOL:

A hard-sided swimming pool installed permanently on the ground surface.”

“PORTABLE POOL:

A soft-sided swimming pool, inflatable or not, designed to be installed on a temporary basis.”

“POOL INSTALLATION:

A swimming pool and any equipment, construction, system and accessory designed to ensure proper functioning of the pool, to ensure the safety of persons or to allow or prevent access to the pool.”

SECTION 2

The paragraph c) “*Mandatory permanent enclosure for an in-ground and semi-inground pool or an above-ground, inflatable, removable pool and spa with a capacity exceeding 2,000 litres requiring the installation of an enclosure*” of article 5.7 of *Zoning By-Law no. 90-58* is repealed and replaced by the following paragraph:

“c) Mandatory enclosure for swimming pool – inground or semi-inground pool, aboveground pool, portable pool and whirlpool or hot tub with a capacity exceeding 2,000 litres

A swimming pool must be surrounded by an enclosure to restrict access. The

enclosure shall be installed so that the pool is separated from the openings of the buildings, the remainder of the yard and its equipment (play structures, outdoor dining set and other similar equipment).

Notwithstanding the foregoing, an area adjoining the pool containing chairs, shade structure, and/or the shed containing the pool installations may be located within the enclosure.

The enclosure must:

- i) be permanently installed and kept in place at all times;
- ii) be securely anchored to the ground;
- iii) prevent the passage of a spherical object 10 cm in diameter;
- iv) be at least 1.2 m in height;
- v) be at a distance of at least 0.75 m from the perimeter of the water surface of the pool in order to maintain a free space around the pool;
- vi) have no fixture, projection or open parts enabling it to be climbed;
- vii) be made of one or a combination of the following materials:
 - tempered or laminated glass panel;
 - wood;
 - metal or chain link;
 - PVC or other similar composite;
 - masonry;
 - heavy-duty PVC, polyester, nylon, or textilene mesh that meets the ASTM F2286-16.

Chicken wire fencing, snow fencing, temporary flexible construction fencing, or similar materials are prohibited.

For the purposes of this article, the height of the enclosure is measured from the top of the enclosure, excluding columns, to any point of the ground within 1 m of the base of the enclosure.

Example of calculation of the height of the enclosure

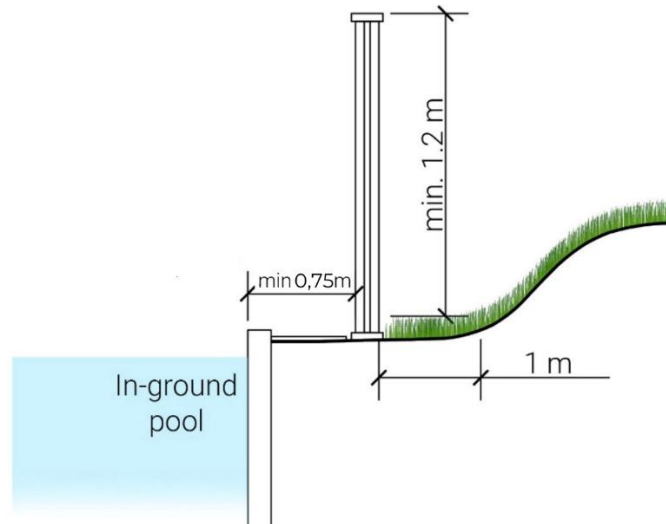

Where the enclosure is a chain-link fence, the mesh must have a maximum width of 30 mm. If slats are inserted in the mesh, their width may be greater than 30 mm but they must not allow the passage of a spherical object more than 30 mm in diameter.

A wall forming part of an enclosure must not have any opening enabling to enter the enclosure. Despite the foregoing, such a wall may have a window if the window is situated at a minimum height of 3 m from the ground on the inside of the enclosure, or, otherwise, if its maximum opening does not allow the passage of a spherical object more than 10 cm in diameter. However, a device that limits the opening of a window cannot be installed on an opening that is intended to be an evacuation means in the event of a fire under the applicable codes and standards (e.g. bedroom window).

A hedge or bushes cannot constitute an enclosure.

In addition to complying with the above features, every gate forming part of an enclosure must also be equipped with a self-closing and self-latching passive security device. The device must be locked or padlocked when the pool is not under the direct supervision of an adult. The device may be installed on the inside of the enclosure in the upper part of the gate or on the outside of the enclosure at a minimum height of 1.5 m from the ground.

Example of a passive security device

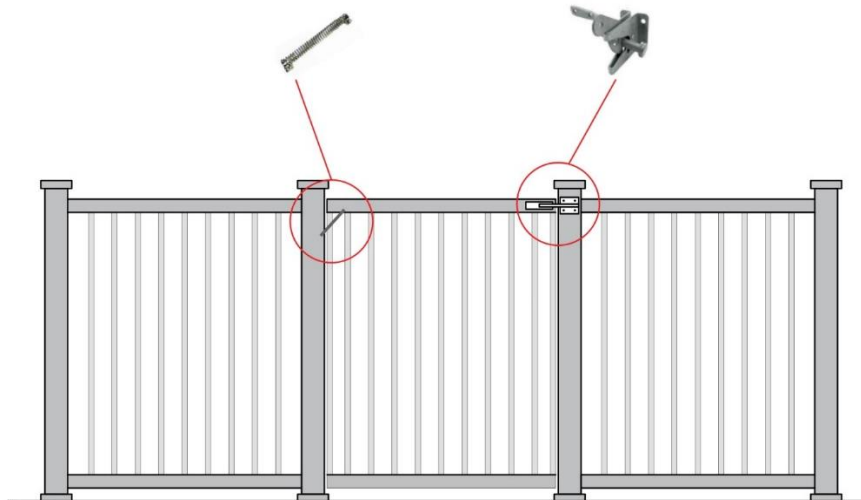

No swimming pool may be filled more than 60 cm before the enclosure is installed in accordance with the foregoing.

During the construction or modification of a pool installation, temporary measures to control access to the pool must be provided. A certificate of authorization is required to make any modification to a pool installation.

Examples of enclosures surrounding a pool

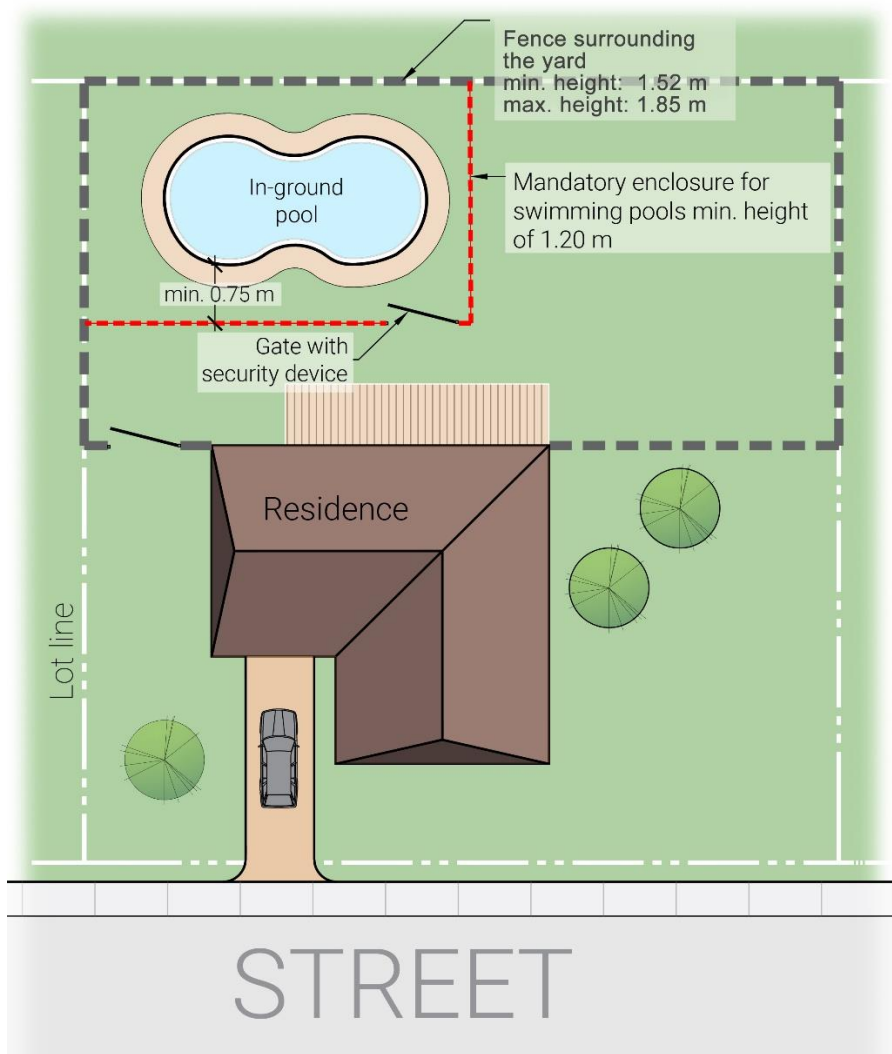

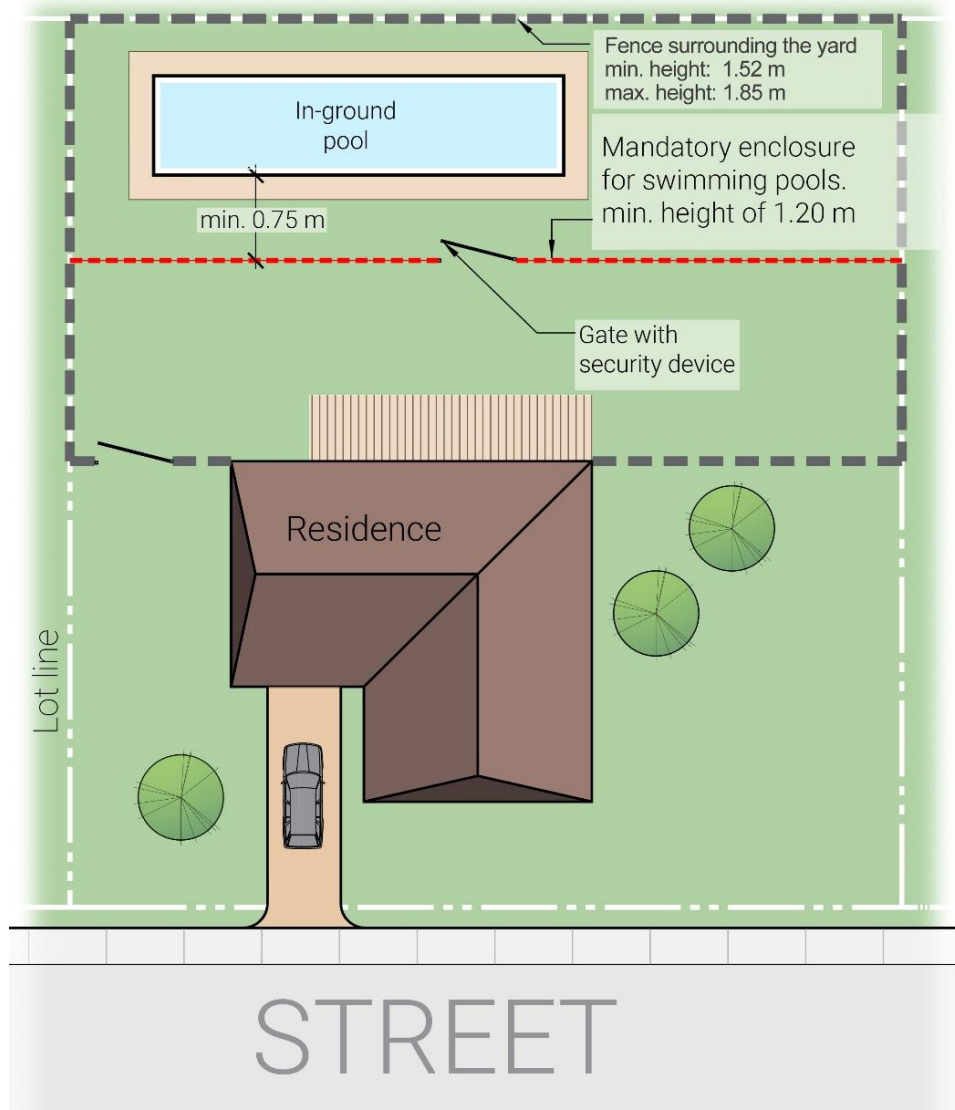

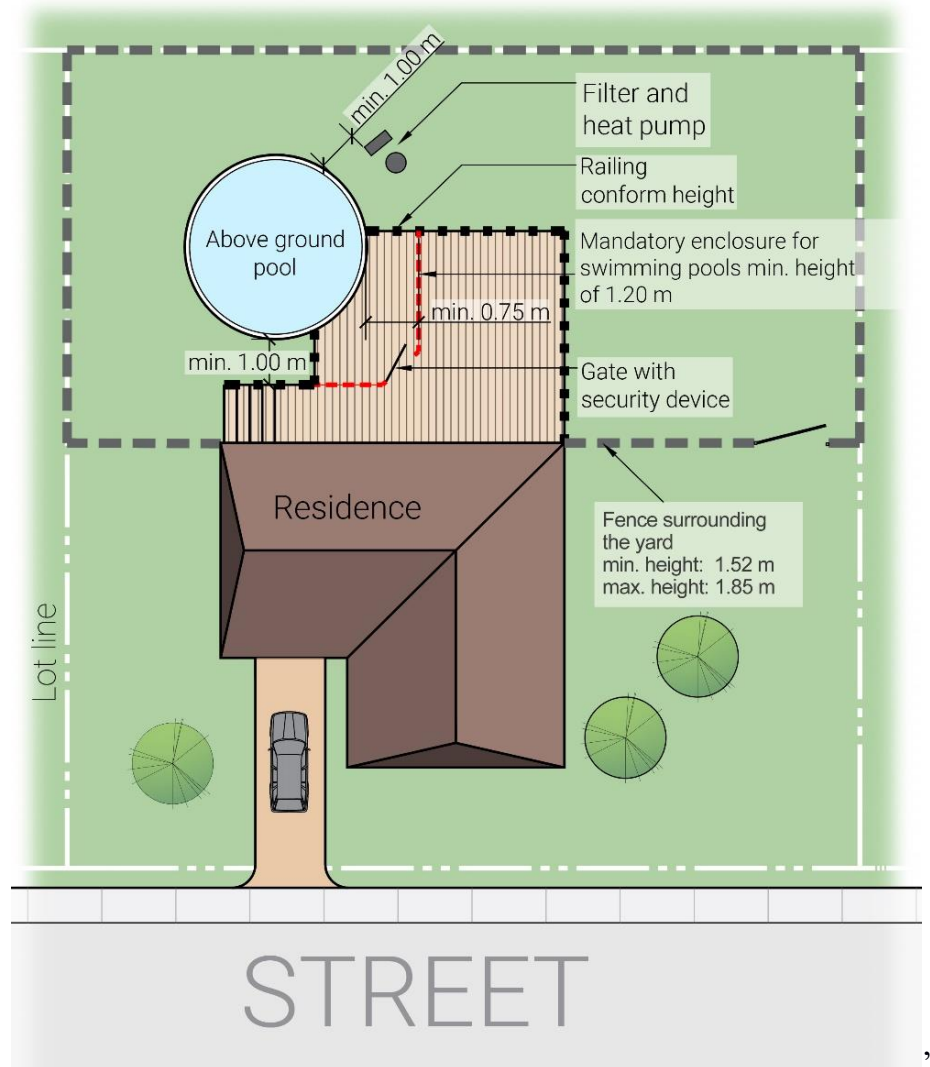

SECTION 3

The paragraph d) “*Safety considerations for out-of-ground pools*” of article 5.7 of *Zoning By-Law no. 90-58* is repealed and replaced by the following paragraph:

“d) *Safety of an aboveground pool or portable pool*

Notwithstanding paragraph c), for any aboveground pool with a wall height of at least 1.2 m from the ground at any point or a portable pool with a wall height of 1.4 m or more is not required to be surrounded by an enclosure if access to the pool is by:

- i) a ladder equipped with a self-closing and self-latching safety gate preventing its use by children. This gate must be locked or padlocked when the pool is not under the direct supervision of an adult;
- ii) a ladder or a platform access to which is protected by an enclosure having the features described in paragraph c); or
- iii) a patio attached to the residence and laid out so that the part giving access to the swimming pool is protected by an enclosure having the features described in paragraph c).”

SECTION 4

Article 5.7 of *Zoning By-Law no. 90-58* is amended by adding paragraph d.1) “*Fence surrounding the yard*”, so that it reads as follows:

“d.1) *Fence surrounding the yard*

Any yard in which a swimming pool, whirlpool or hot tub is located must be surrounded by a fence of a minimum height of 1.52 m installed on or near the property lines.”

SECTION 5

The paragraph e) “*Safety ladders*” of article 5.7 of *Zoning By-Law no. 90-58* is repealed and replaced by the following paragraph:

“e) Ladder or steps

All inground and semi-inground pools must be equipped with a ladder or steps used to enter or exit the water.”

SECTION 6

The paragraph g) “*Slope and change of depth*” of article 5.7 of *Zoning By-Law no. 90-58* is repealed.

SECTION 7

The paragraph h) “*Diving boards*” of article 5.7 of *Zoning By-Law no. 90-58* is repealed and replaced by the following paragraph:

“h) Diving board

A swimming pool with a diving board must be installed in accordance with BNQ Standard 9461-100 “Residential Swimming Pools Equipped with a Diving Board – Minimum Water Envelope to Prevent Cervical Spinal Cord Injuries Resulting from Diving from a Diving Board” in force at the time of the installation.”

SECTION 8

The paragraph i) “*Operating device and structures*” of article 5.7 of *Zoning By-Law no. 90-58* is repealed and replaced by the following paragraph:

“i) Operating devices and structures

In order to prevent children from climbing to gain access to the swimming pool, every device linked to its operation must be installed more than 1 m from the pool wall or, as the case may be, the enclosure.

The pipes linking the device to the swimming pool must be flexible and not be installed in a way that facilitates the climbing of the pool wall or, as the case may be, the enclosure.

Despite the first subparagraph, a device may be less than 1 m from the swimming pool or enclosure if it is installed:

- i) inside an enclosure having the features described in paragraph c);
- ii) under a structure that prevents access to the swimming pool from the device and that has the following features:
 - be at least 1.2 m in height; and
 - have no fixture, projection or open parts enabling it to be climbed.
- iii) in a shed.

A structure or fixed equipment likely to be used for climbing over the wall or the enclosure must also be installed at more than 1 metre from the pool wall or, as the case may be, the enclosure. That minimum distance applies to a window situated less than 3 m from the ground, except if its maximum opening does not allow the passage of a spherical object more than 10 cm in diameter.”

SECTION 9

Article 5.7 of *Zoning By-Law no. 90-58* is amended by adding paragraph j) “*Maintenance*”, so that it reads as follows:

“j) *Maintenance*

Every pool installation intended to allow or prevent access to the swimming pool must be kept in good working order.”

SECTION 10

Article 5.7 of *Zoning By-Law no. 90-58* is amended by adding paragraph k) “*Application*”, so that it reads as follows:

“k) *Application*

Article 5.7 of this by-law applies to any new pool installation installed as of July 1st, 2021. Despite the foregoing, the sixth subparagraph of paragraph c), paragraph h) and the fourth subparagraph of paragraph i) of article 5.7 do not apply to a new pool installation acquired before that date, provided that such a pool installation is installed not later than September 30, 2021.

It also applies to a pool installation existing before July 1st, 2021, except the sixth subparagraph of paragraph c), paragraph h) and the fourth subparagraph of paragraph i) of article 5.7. Such a pool installation existing before November 1st, 2010 must comply with the applicable provisions of this by-law not later than July 1st, 2023.

Re-installing a swimming pool referred to in the second subparagraph of this paragraph on the same ground does not make the sixth subparagraph of paragraph c), paragraph h) and the fourth subparagraph of paragraph i) of article 5.7 applicable to the pool installation that includes the pool. Despite the foregoing, when such a pool is replaced, the existing pool installation must then comply with those provisions.

Notwithstanding the Town’s *By-law Establishing Tariffs for certain municipal services*, a permit to bring a pool installation into compliance with this by-law shall be issued free of charge for a pool installation existing before November 1st, 2010 and for which a permit had been issued.”

SECTION 11

Article 1.7 of *Zoning By-Law no. 90-58* is amended by adding the following paragraph, after paragraph a.1):

“a.2) Notwithstanding article 1.7 a), a swimming pool owner who contravenes a provision of article 5.7 of this by-law is liable to the following fine:

- *for a first infraction*: a minimum of **FIVE HUNDRED DOLLARS** (\$500) and a maximum of **SEVEN HUNDRED DOLLARS** (\$700);
- *for a subsequent infraction*: a minimum of **SEVEN HUNDRED DOLLARS** (\$700) and a maximum of **ONE THOUSAND DOLLARS** (\$1,000).”

SECTION 12

The present by-law comes into force according to law.

(Michel Gibson)

Mayor

(Annie Riendeau)

Town Clerk